



ISSUE 2

# Fortress Dömitz

STRUCTURAL ELEMENT: SANDSTONE PORTAL

Documentation of a Restoration and Repair Project

**Baltic Fort Route**

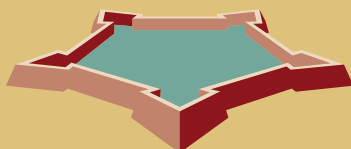

This project is part-financed by the European Union (European Regional Development Fund) within the BSR INTERREG III B programme

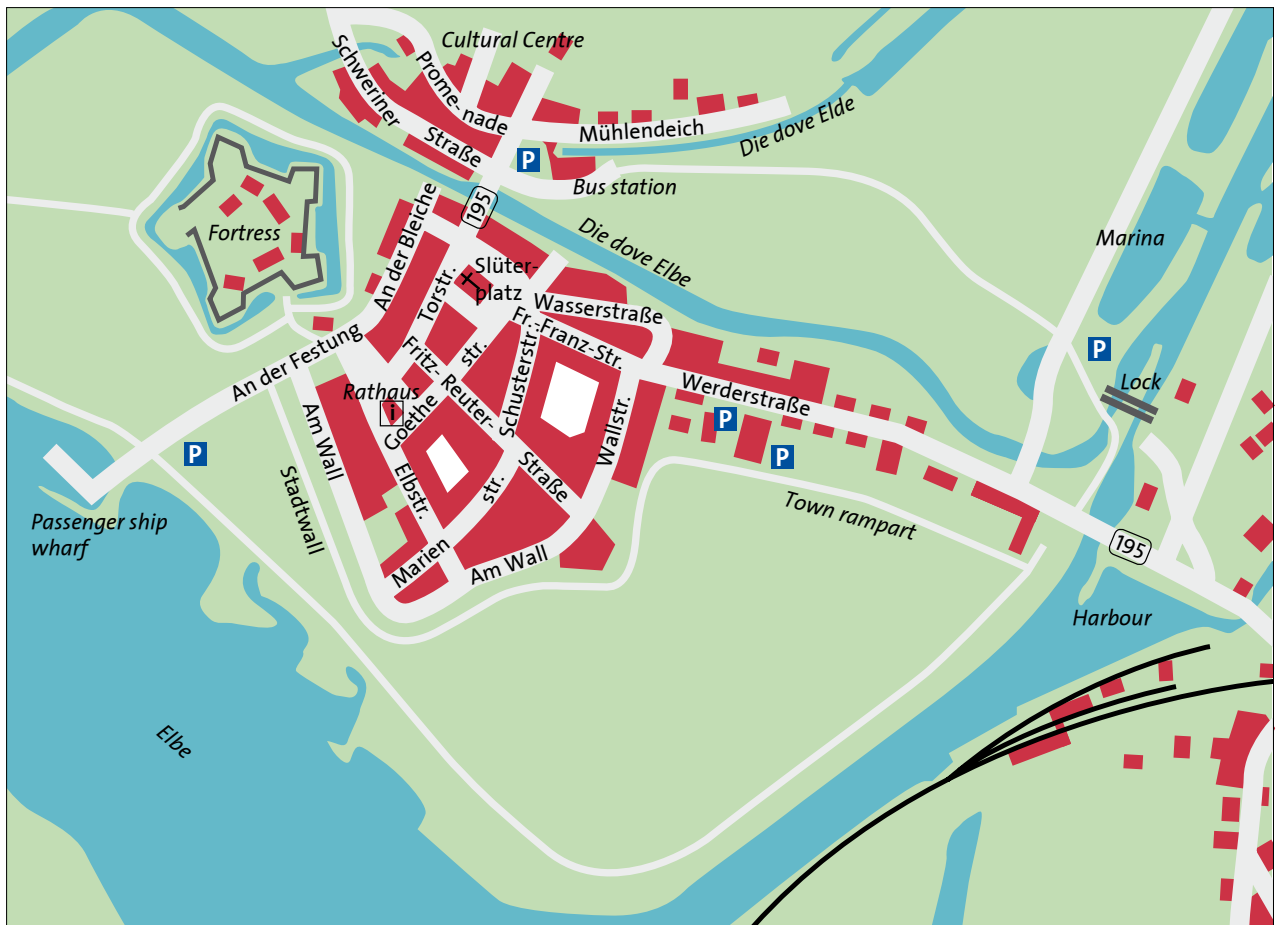

**Ground plan of fortress complex, right:**

- |  |  |
|--|--|
| 1 - Kommandantenhaus (commander's house)             | 12 - "Cavalier" Bastion  |
| 2 - Remise (coach house)                             | 13 - "Held" Bastion  |
| 3 - Zeughaus (armoury)                               | 14 - "Drache" Bastion  |
| 4 - Freilichtbühne (open-air theatre)                | 15 - "Greif" Bastion   |
| 5 - Kanonenrampe (cannon ramp)                       | 16 - "Burg" Bastion  |
| 6 - Blockhaus (block house)                          | 17 - Curtain walls   |
| 7 - Hauptwache (main guard building)                 | 18 - Flank of bastion  |
| 8 - Arrestantenhaus (prison building)                | 19 - Face of bastion   |
| 9 - Wallmeisterhaus (fortification official's house) | 20 - Fortress ditch, counterscarp  |
| 10 - Gateway to outer ward                           | 21 - Rampart, glacis, covered way, assembly areas for defending infantry |
| 11 - Casemates                                       |  |

# Table of Contents/Ground Plan of Fortress Complex

Map of Dömitz/Ground Plan of Dömitz Fortress	0
Table of Contents/Ground Plan of Fortress Complex	1
1. Preface	2
2. The Sandstone	6
3. Anchors, Mortar and Concrete	10
4. Moisture and Salt Contamination of the Sandstone	12
5. Damage on the Sandstone Portal	14
6. Project Planning for the Restoration of the Sandstone Portal	18
7. Restoration Measures	20
7.1 Cleaning	20
7.2 Reduction of the Salt Content	20
7.3 Dismantling and Re-setting of Severely Displaced Structural Elements	22
7.4 Plumbing Work	24
7.5 Moisture Barrier between Portal Sandstone Elements and Brick Wall	26
7.6 Masonry Unit Replacement and Stone Grafts	27
7.7 Strengthening Areas of Granular Disintegration	29
7.8 Backfilling of Plates/Contour Scaling and Repair of Cracks	29
7.9 Repair Work with Stone Repair Compounds	30
7.10 Retouching Repair Work	30
7.11 Joint Repair	31
8. The Sandstone Portal Following Completion of Restoration Work	32
Appendix - Bibliography/List of Parties Involved	36
Imprint	37



# 1. Preface



Situated on the Mecklenburg banks of the Elbe River the Dömitz Fortress is one of the few well preserved flatland fortresses from the 16th century in northern Europe. Designed in the shape of an equilateral pentagon with bastions and casemates the fortress is an impressive example of Renaissance defence architecture.

Johann Albrecht I (1525-1576), duke of Mecklenburg-Güstrow, recognised the economic and strategic importance of Dömitz's location and ordered the building of a fortress there on the remains of an earlier structure from the 13th century. This new fortress, the strongest in the land, was built at great expense between the years of 1557 and 1565 and enabled Mecklenburg to secure its border and control the collection of customs duties for the Elbe River.

Duke Johann Albrecht I maintained relationships with many European courts and engaged the services of artists of all genres from the leading cultural centres of the period. Other significant buildings attributed to this dynamic territorial lord are the old Schwerin Castle and the well-preserved Castle of Gadebusch. For the construction of the Dömitz Fortress he hired the Brescian castle builder Francesco a Bornau, who was a prominent expert on defence architecture and had constructed the bastions for the Schwerin Castle.

Over the past centuries all of the structures built by Francesco a Bornau inside the fortress, except for the Kommandantenhaus (commander's house), have been replaced by new structures. However, the fortress complex as a whole has been preserved in its original form to the present day.

As defensive structures fortresses are designed for fortification, both in their ground-plan and elevation. The architecture must ensure effective lines of fire for the defensive firearms and the absence blind spots.

With their bastions and ramparts fortress structures have rather austere and forbidding functional architectures with military character. The only area which was generally designed with special lavishness and significance was the fortress entrance. This phenomenon can also be observed in Dömitz.

The entrance to the Dömitz Fortress is an extravagantly designed portal built onto the side of the "Cavalier" Bastion. The simple fact that sandstone was used, a material which had to be transported several hundred kilometres along the Elbe waterways, is a good indication of the high standards held by the builder in the design of the entrance area.

The portal was erected in late Dutch Renaissance style, and it can be assumed with relative certainty that the structure was originally part of a gatehouse. The vaulted gateway is flanked by pilasters and crowned by a cornice whose architrave is decorated with reliefs of lion heads and lion masks. The framed inscription

"JOHANNES ALBERTUS DUX MEGAPOL SIBI-SVISQVE COMMUNIVIT ANNO M D LXV»

(Erected by Johann Albrecht of Mecklenburg for him and his in 1565)

can be seen in the centre of the architrave.

Portrait medallions, one with a woman's face and one with a man's, are built into the spandrels on either side of the vaulted arch.

The cornice is surmounted by a pediment with a tympanum; the plates beneath the tympanum are flanked by volutes and pilasters and decorated with two coats of arms: the Mecklenburg coat of arms for Duke Johann Albrecht I on the left and the Brandenburg coat of arms for his wife, Anna Sophia, on the right.

The soldier's head which rests atop the tympanum was created in 1986 by the sculptor G. Hampel from artificial stone. The original head was lost in World War II.

A side entrance for pedestrian traffic only was built beside the gateway. The design of the jambs and the vaulted arch corresponds to that of the gateway. The doorway is surmounted by a triangular pediment whose left lower corner is cut off by the pilaster between the gateway and the side entrance. This apparent design inconsistency leads one to speculate whether design changes may have taken place in connection with restoration work or whether the portal may have been planned for a different site and reused at this location.

The sandstone portal has undergone restoration on two previous occasions. This fact is apparent in the differing building materials and workmanship. A sandstone-framed





plaque in the curtain wall beside the fortress entrance states that the fortress underwent restoration between 1851 and 1865. Further restoration work was performed in the 1930s.

Below:

Fig. 1 - Depiction of the fortress complex at the end of the 17th century by A. F. Lorenz/Collection of Museum Festung Dömitz from: Jürgen Scharnweber, *Festung Dömitz*, 1995, p. 39

Fig. 2 - Photograph taken of the portal around 1920, Postcard/from the Collection of the Museum Festung Dömitz

Fig. 3 - Photograph showing the "Cavalier" Bastion with the fortress entrance (outer gate) and the sandstone portal

Fig. 4 - Photograph showing the sandstone portal of the Dömitz Fortress

Fig. 5 - View from the entrance casemate through the portal

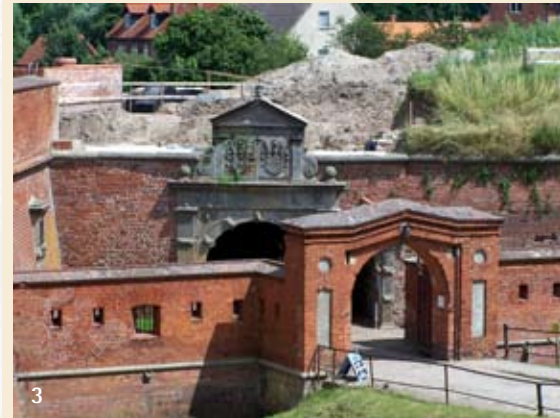
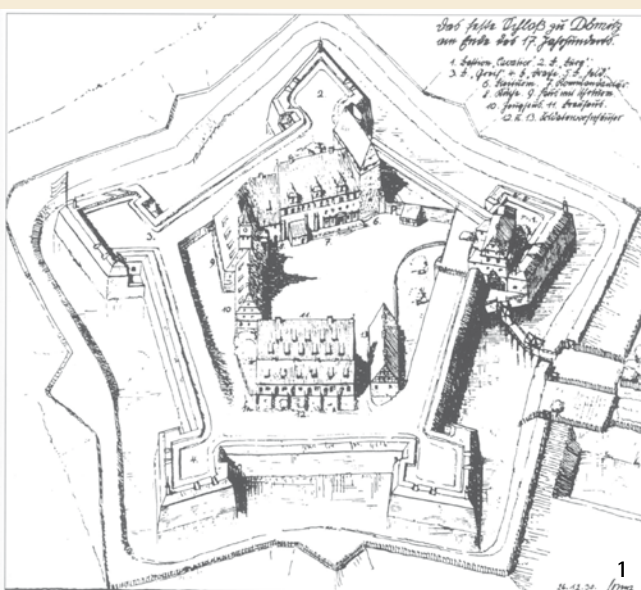

The restoration of the Dömitz Fortress, which began in 2001, also involved the restoration of the sandstone portal. This work was performed in the context of the EU project Interreg III B "BalticFortRoute" in scientific cooperation with EU partners in Poland, Lithuania and Germany.

Extensive preliminary site investigations were performed in 2005 in preparation for the restoration.

As a basis for the structural condition assessment a site measurement of the portal was performed manually, taking all deformation into account. The structural condition and discernible damages were documented photographically and diagrammed in the planning documents.

A plan for investigating the building stock and analysing structural materials on the sandstone portal of the Dömitz Fortress was developed on the basis of visual appraisals after thorough inspection of the structure. Special attention was given to indications of high moisture and salt

content in the sandstone elements and the adjacent walls; these factors are recognised as major causes of weathering damage in the sandstone elements of the structure.

The restoration technologies developed from the findings of the investigations were then tested on a sample axis on the portal. Restoration work on the portal was completed in the spring of 2007.

*Below - Top section of the portal*







Left and below:

Fig. 1 - Inscription on the architrave

Figs. 2/3 - Mecklenburg coat of arms for Duke Johann Albrecht I and Brandenburg coat of arms for his wife, Anna Sophia

Figs. 4-6 - Details on the portal, portrait reliefs and lion head on the archway



## 2. The Sandstone



Upon thorough inspection of the object it becomes apparent that various types of sandstone were used for the portal, or added during later restoration work. The sandstone types vary in structure, texture, grain size and colour, as well as in fossil content and weathering behaviour.

Based on these macroscopic properties it was possible to visually identify four different types of sandstone.

Most of the sandstone pieces used in the gateway were made from either a medium-grain yellow sandstone with ferritic (iron-bearing) inclusions and banded structures or a medium-grain grey sandstone with scattered fossil impressions. Owing to their frequency of occurrence these types of sandstones are believed to have been the original building materials.

Several smaller stone segments used for repairs (stone grafts) and parts of the triangular pediment over the side entrance are made of a fine-grain grey sandstone with a lamination indicated by thin, dark grey flasers. This sandstone appears to have been used for the restoration work performed between 1851 and 1865. This assumption is supported by the fact that the frame of the commemorative plaque in the curtain wall beside the fortress entrance was also made from this grey, fine-grain variety of sandstone.

Some other repair segments, along with the raking cornice of the pediment above the reliefs of the two coats of arms, are made from a fine-grain yellow sandstone with round and elongated fossil impressions. The fact that saw marks are discernible on the crowning tympanum of the portal's top section suggests that this sandstone was used for the restoration work performed in the 1930s. The use of frame saws for stone-cutting was not common until after 1870.

In order to classify the sandstone, rock samples 1 to 2 cm in size were taken from the four identified varieties. Thin sections made from these samples were petrographically analysed using a polarising microscope. Based on these analyses the two medium-grain sandstone varieties used for the original construction were classified as Posta-type Elbe sandstones, and the two fine-grain sandstones used for later restoration work on the portal were identified as belonging to the Elbe sandstone variety Cotta.

The differentiation between Posta and Cotta sandstones is an established system of classification for rock taken from the Elbe Sandstone Mountains. These sandstone varieties have been named for the places where their prototypes were quarried, or are still quarried to this day: Posta, now a district of the city of Pirna, and Cotta, a village west of Pirna.

A large number of quarries, both historical and operational, are located in the sandstone quarrying region whose German territory stretches along both sides of the Elbe river from the Czech border to Pirna and is defined regionally-geographically as the Elbe Sandstone Mountains or Sächsische Schweiz (Saxon Switzerland).

The qualities of rock extracted here as building stone and cut stone can vary, not only among quarries but also within the same quarry, where various qualities of rock can be extracted at different quarry horizons.

The differentiation between Posta and Cotta varieties of Elbe sandstone is oriented more toward their basic building-stone qualities than their origins.

Posta-type Elbe sandstones are characterised by their high strength. This type of rock is primarily used for load-bearing structures and in heavily loaded building structures (plinth trims) as well as for floor and paving slabs, steps and kerbstones. This type of sandstone also exhibits good resistance to weathering.

When directly exposed to the influences of weather Posta-type Elbe sandstones will turn black in a relatively short period of time owing to the process of patination.

Their strength and granularity make them difficult to carve and cut. Therefore working with this type of sandstone is a more labour intensive and time consuming process, associated with high tool wear. Its suitability for fine carving work is limited.

Cotta-type Elbe sandstones have a lower strength and are very fine-grained. Therefore this type of rock is characterised by especially good working properties and exhibits a good edge strength. As a result it is a preferred choice of material for fine profiling and sculpting work.

However, its resistance to weathering is moderate to low. This is especially true when exposed to frequent or constant moisture penetration (rising damp, splash water). Some typical weathering effects are flaking and relief-like back weathering along clay flasers and fossil impressions. It



seems that several of the stone grafts made from this type of sandstone began to show signs of damage within just a few decades and had to be repaired with cement mortar during later restoration work.

Sandstones from the quarrying regions of Saxony were used in especially large quantities in the regions east of the Elbe River until the second half of the 19th century because, prior to the railway age, transport by water via the Elbe and Havel rivers represented practically the only possibility for transporting loads of that size over great distances.

It is impossible to determine with certainty from which quarry or quarrying region each of the four sandstone varieties originated. However it can be said with relative

confidence that at the time when the fortress was built – during the 2nd half of the 16th century – Posta-type sandstone was mined primarily, if not exclusively, in the Posta and Postelwitz quarries and shipped on the Elbe. The medium-grain yellow sandstone with ferritic inclusions and banded structures corresponds to sandstone from the Posta quarries, while the medium-grain grey sandstone with scattered fossil impressions is macroscopically similar to sandstone from the Postelwitz quarries. Both quarries are no longer in operation.

The fine-grain grey sandstone with a lamination indicated by thin, dark grey flasers corresponds macroscopically to sandstone from the Neuendorf quarries. The fine-grain yellow sandstone with round and elongated fossil impressions may have come from the Lohmgrund quarries.

Below:

Fig. 1 - Thin section photomicrograph, medium-grain sandstone

Fig. 2 - Thin section photomicrograph, fine-grain sandstone

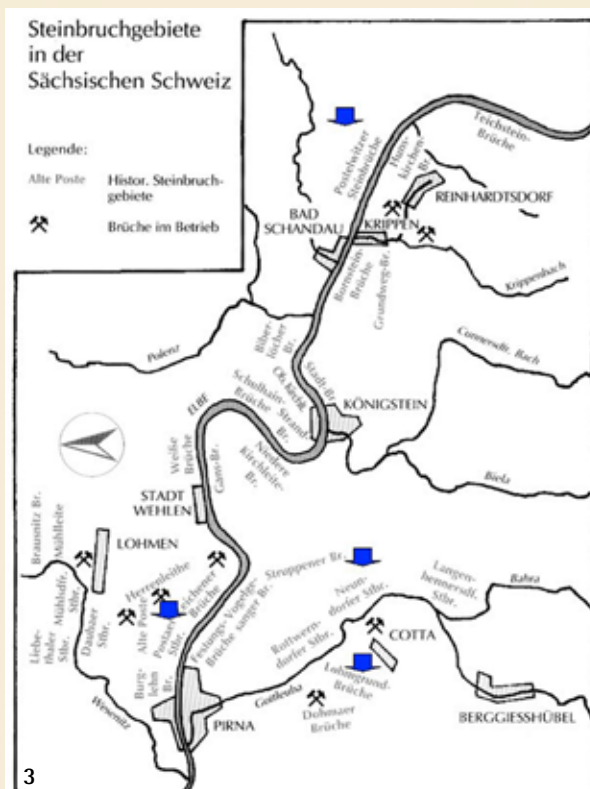

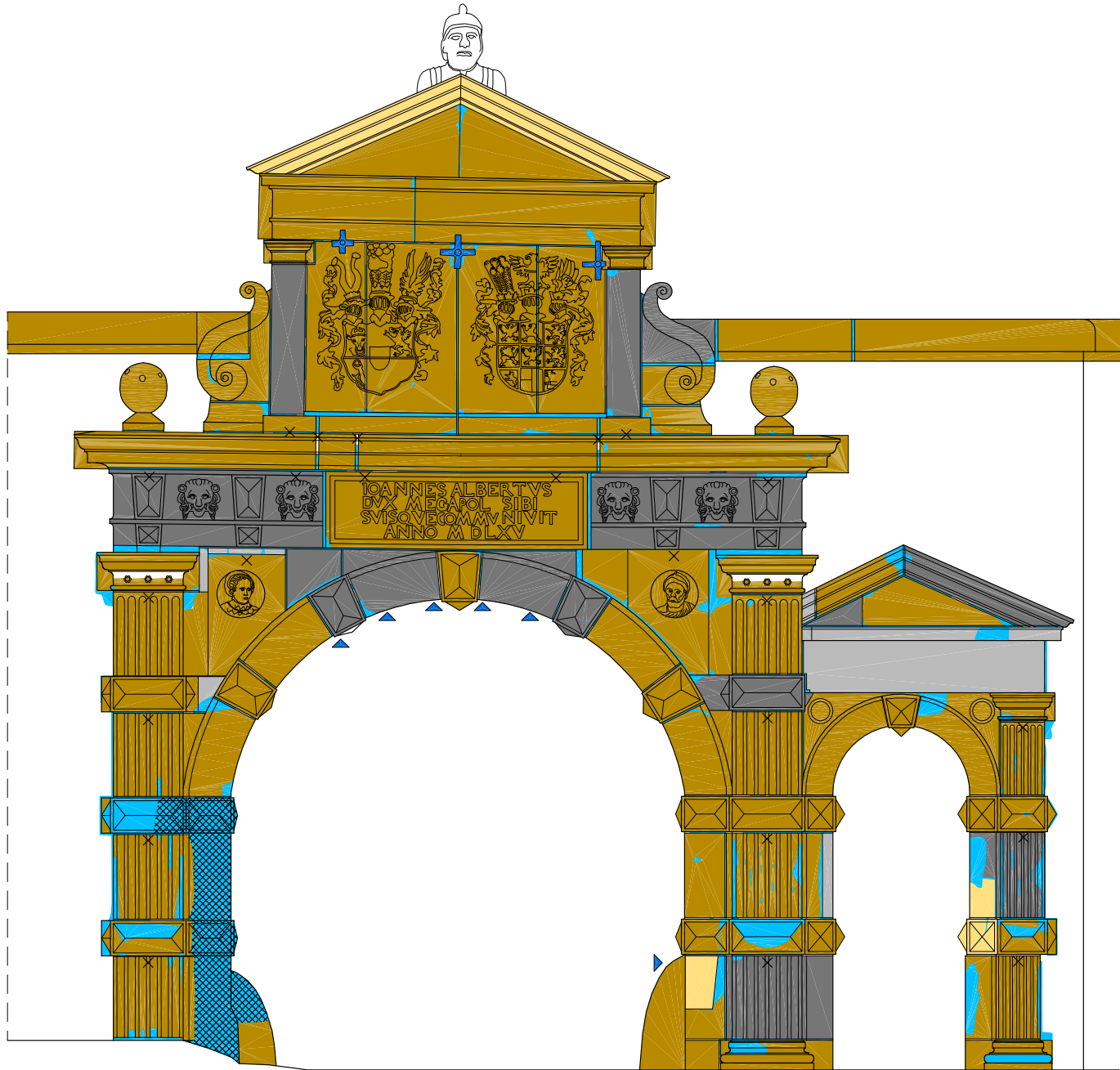

TYPE OF MAPPING		SITE	OBJECT	STRUCT. ELEMENT/AREA
MATERIAL MAPPING		DÖMITZ FORTRESS	SANDSTONE PORTAL	VIEWS
COLOUR	SYMBOL			
		COTTA SANDSTONE, GREY		
		COTTA SANDSTONE, YELLOW		
		POSTA SANDSTONE, YELLOW, BANDED		
		POSTA SANDSTONE, GREY, FOSSIL-CONTAINING		
		MORTAR ON BRICKWORK		
		REPAIR MORTAR		
		VISIBLE IRON ELEMENTS		
		DETECTED IRON ELEMENTS		

DÖMITZ FORTRESS  
SANDSTONE PORTAL  
MATERIAL MAPPING 2005

Working Group  
Thomas Bolze, engineer  
Thomas Schuber, restorer

Above - Material Mapping





*Above and right:*

*Fig. 1 - Medium-grain yellow Posta sandstone with ferritic inclusions and bands (original building material)*

*Fig. 2 - Medium-grain grey Posta sandstone with scattered fossil impressions (original building material)*

*Fig. 3 - Fine-grain grey Cotta sandstone with a lamination indicated by thin, dark grey flasers (used for repair work at the end of the 19th century)*

*Fig. 4 - Fine-grain yellow Cotta sandstone with round and elongated fossil impressions (used for repair work around 1930)*



### 3. Anchors, Mortar and Concrete



The entire natural stone construction of the portal is superimposed on the wall construction of the bastion and the entrance casemate. Although the portal is constructed of solid masonry units its stability can only be guaranteed through functional anchoring against the supporting wall. Anchors are embedded with hooks in the horizontal joints of the masonry units and fixed to the rear wall with masonry bolts. These anchors are not visible from the outside.

The locations of the anchors were determined using a metal detector and recorded on the Material Mapping. The anchoring system for the lower portion of the portal was found to be relatively evenly distributed. Every masonry unit of the gateway jambs and the cornice above them is secured by at least one anchor.

The top section of the portal, however, is supported by only the three visible anchors, which were probably added during later restoration work. The degree of rusting was estimated visually by means of endoscopic analyses on two of the wrought-iron anchors. Although rust formation is visible and the entire top section of the portal appears distorted, the load-bearing capacity of the anchors was determined to be sufficient – owing in part to their generous dimensions.

In order to create an even surface along the inside of the jambs and the archway for the gates to close against, the uneven sandstone blocks had been evened out with a layer of roofing tiles held in place with mortar. In the archway area these tiles had been fastened with anchors to prevent them from loosening and falling off.





During the restoration work that was performed on the portal around the year 1930, missing sandstone units and sandstone units with very large flaws in the left gateway jamb were filled in with brickwork. This brickwork was built using industrially manufactured vertical coring bricks and plastered with cement mortar.

In preparation for our restoration work it was necessary to determine the composition of the historic mortar used. For this purpose samples were taken of the construction, joint and repair mortars and analysed to determine the binder content and the grain-size distribution of the aggregates. These analyses revealed that a lime mortar was used for the original construction, while later repair work was performed using cement as binder.

The sculpture of the soldier's head set atop the tympanum on the upper section of the portal is a reconstruction by the sculptor G. Hampel from 1986 made from artificial stone. The original sculpture, which is shown slightly out of focus in a pre-1900 photograph from the collection of the Museum Dömitz, was evidently lost, as were the two sections of raking cornice on the pediment that were replaced in the 1930s.

Left:

*Fig. 1 - Wrought-iron anchor for the sandstone units with the coat-of-arms reliefs in the pediment (top section of portal)*

*Fig. 2 - Wrought-iron anchors for the mortared roofing tiles which were added to even out the jambs*

*Fig. 3 - Anchor for the guardstone on the right jamb of the gateway*

*Fig. 4 - Plastered brickwork used for filling out the left jamb of the gateway in later restoration work*

Below:

*Fig. 1 - Sculpture of the soldier's head atop the pediment of the gateway*

*Fig. 2 - Mounting of the head by the sculptor G. Hampel and workers from the Dömitzer Gebäudeverwaltung on 9 September 1986, from: Jürgen Scharnweber, Festung Dömitz, 1995, p. 117.*





## 4. Moisture and Salt Content of the Sandstones



The sandstones of the portal showed clear signs of surface weathering.

In order to identify the causes for these chemical-physical weathering processes, along with the factors promoting them, the moisture and salt content of the sandstone elements and the adjacent brickwork was investigated.

The moisture analysis was carried out using the microwave moisture measurement system MOIST from the company hf sensor.

The microwave method falls under the category of dielectric moisture measurement. Dielectric measurement processes are based on the unique dielectric properties of water. Water is a polar molecule, meaning that the centres of charge do not coincide within the molecule. Therefore the water molecule orients itself in a preferential direction within an applied field; it is polarisable. If an electromagnetic alternating field is applied the molecules begin to rotate with the frequency of the field (orientation polarisation). This effect is described macroscopically by the physical quantity Dielectric Constant ( $k$ ).

The brickwork areas were examined using the surface sensor, which is able to measure moisture distribution within approx. 3 cm of the surface, as well as the volume sensor, which has a measuring depth of approx. 30 cm.

Sandstone elements were only examined with the surface sensor because most of these blocks have thicknesses of less than 30 cm.

Using the corresponding analysis program the moisture content can be determined in mass% and the moisture distribution data represented graphically.

*Below:*

*Fig. 1 - Moisture analysis using the microwave measurement system MOIST from the company hf sensor*

*Fig. 2 - Measured moisture content of the pilaster sandstone left and right of the gateway. The high values measured in the upper right section can be attributed to water run-off from the side pediment.*

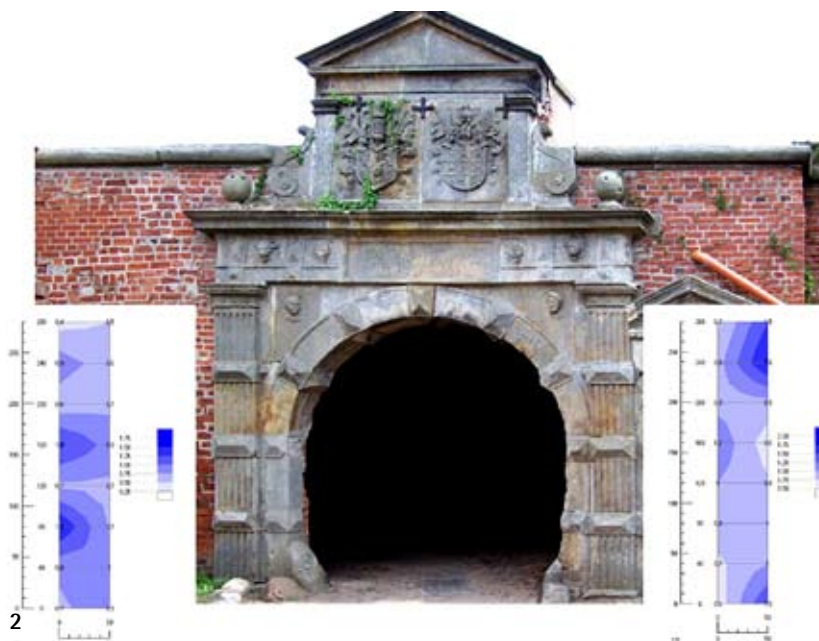





Measurements taken on the brickwork revealed high moisture content in all sections of the wall up to a height of approx. 1.40 m; the moisture content for some areas was found to be at near saturation. This moisture is most certainly the result of rising damp from the ground.

Measurements taken on the sandstone pilasters showed a similar condition. Here, however, we must assume that the moisture is migrating from the adjoining brickwork beside and behind the sandstone.

Measurements taken on the sandstone elements above the archway and main cornice revealed increasing moisture values from top to bottom. The reason for this phenomenon was the penetration of rainwater into the structural elements from above.

In summary it was found that the moisture content of the sandstone that makes up the portal is high, and in some areas extremely high. The reasons for the penetration of moisture, along with rising damp in the brickwork, were the uncovered plates of the cornices that form the upper surfaces of the structure, open joints and seepage water from the bastion. A direct relationship was observed between moisture content and sandstone damage.

In order to investigate the content of structurally damaging salts in the sandstone and the adjacent brickwork various

types of samples were taken. One non-destructive method for sample collection is the scratch test; for this test, samples are taken of deposits or efflorescence from the surface only. Scratch tests, however, are only useful in determining the chemical composition of the salts, not the quantitative salt content of the structural material.

In order to perform a complete salt analysis the collection of drill dust samples was necessary. For this method a 6-8mm carbide bit is drilled into the structural material, and the drill dust collected.

The salt analyses revealed that the salt content of the portal sandstone varies greatly. The area above the archway, for example, was found to have a salt content near zero, while a high content of structurally damaging salts was found in the jambs and pilasters owing to rising damp from the adjacent brickwork.

Below:

Fig. 1 - Measurements taken in the coat-of-arms area of the top portal section

Fig. 2 - Mapping of the collected samples and their salt content

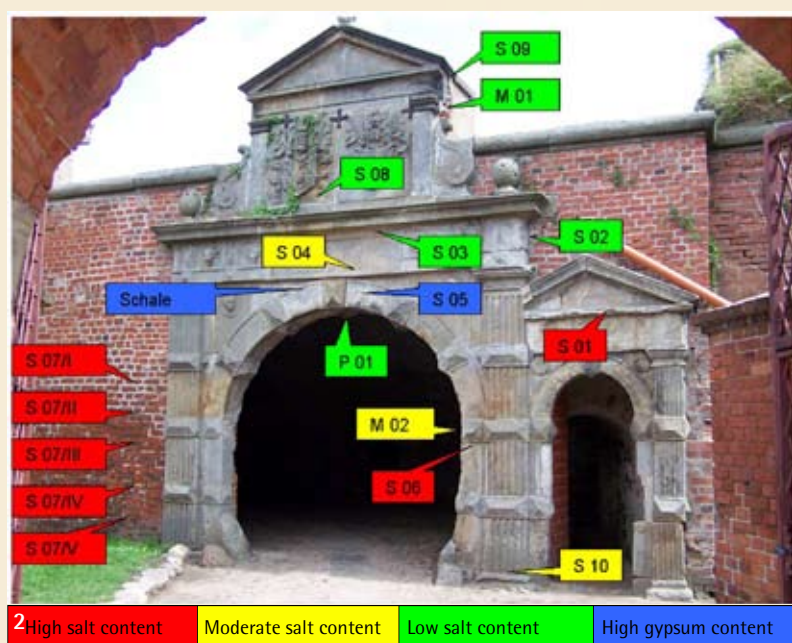
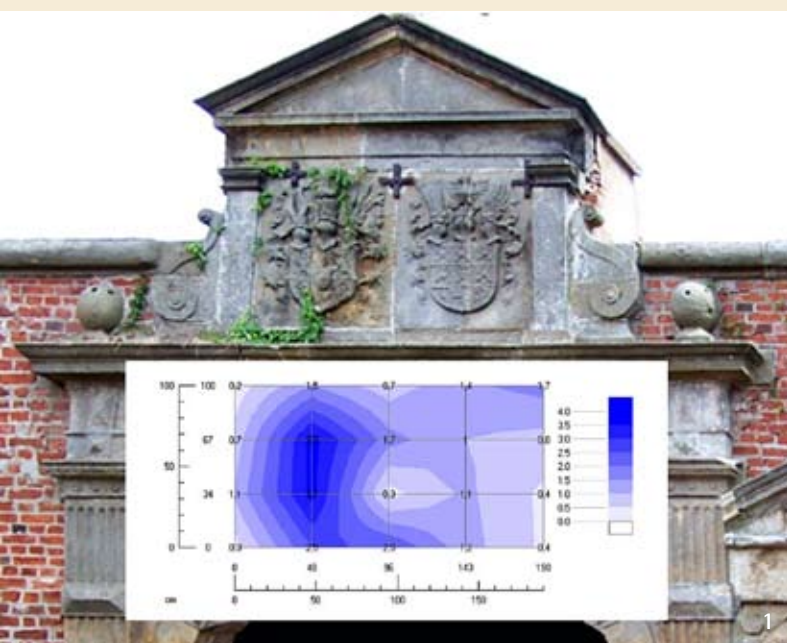

# 5. Damage on the Sandstone Portal

Along with the damage closely associated with the moisture and salt content of the sandstone numerous other types of damage were observed during the preliminary investigation. All observed damage was documented in the form of a Damage Mapping.

*Below - Damage Mapping*

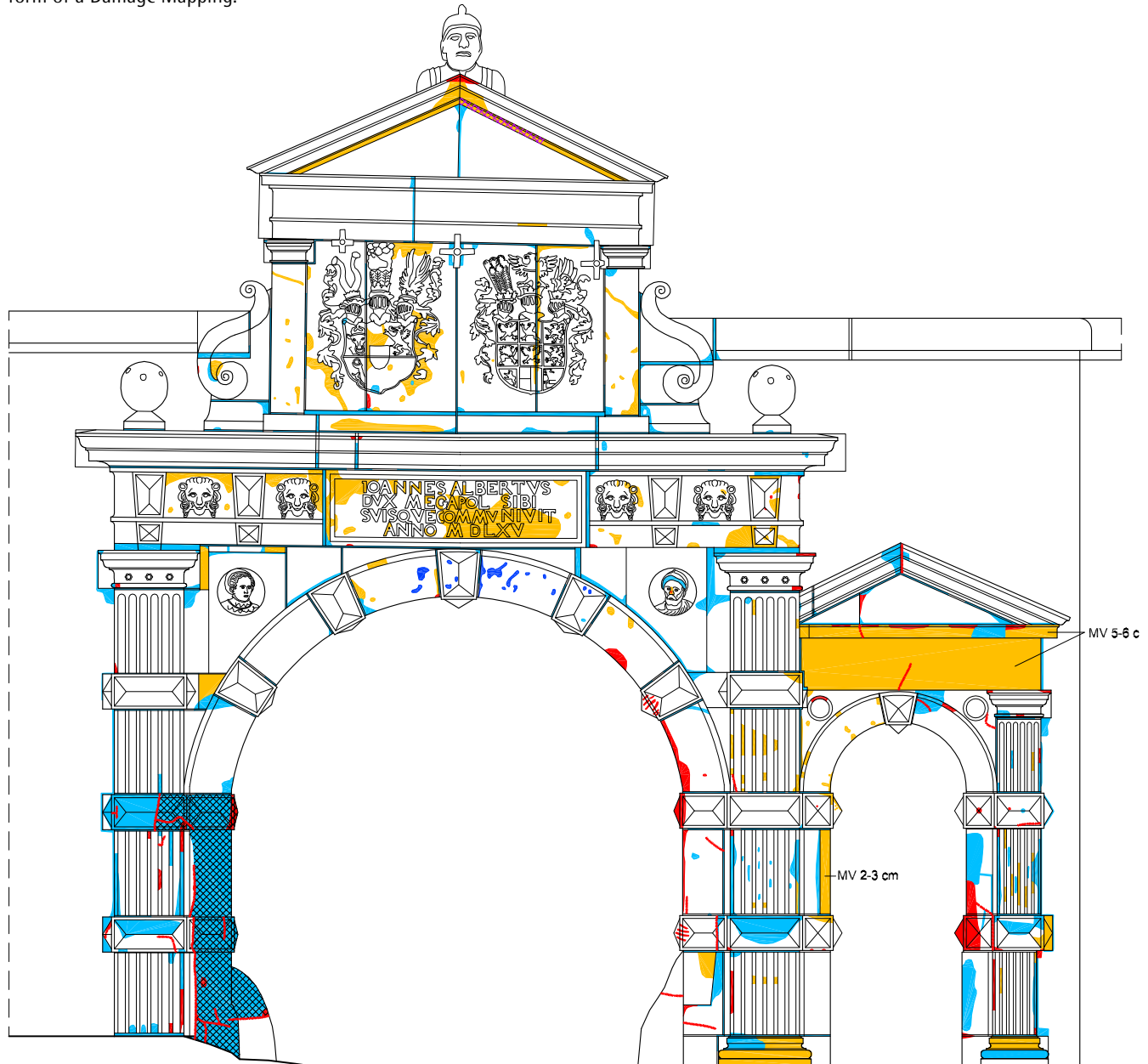

TYPE OF MAPPING		SITE	OBJECT	STRUCT. ELEMENT/AREA
DAMAGE MAPPING		DÖMITZ FORTRESS	SANDSTONE PORTAL	VEWS
COLOUR	SYMBOL			
[Red]		BREAK OUT / FLAWS		
[Blue]	[Red wavy line]	CRACKS		
[Yellow]		GRANULAR DISINTEGRATION		
[Blue]		CONTOUR SCALING		
[Purple hatched]		CRUSTS		
[Light blue]		REPAIR MORTAR		
[Dark blue hatched]		MORTAR ON BRICKWORK		

DÖMITZ FORTRESS  
SANDSTONE PORTAL  
CONDITION ASSESSMENT 2005

Working Group  
Thomas Bolze, engineer  
Thomas Schuber, restorer





*Above and left:*

*Fig. 1 - Soiling and blackening on the surface of the sandstone*

*Fig. 2 - Biological colonisation*

*Fig. 3 - Colonisation of the sandstone surface by lichens*

*Fig. 4 - Differential erosion and break outs on the side portal pediment*

*Fig. 5 - Displacement in the top section of the portal above the gateway*

*Fig. 6 - Displaced masonry units of the pilaster beside the coat-of-arms relief*

*Fig. 7 - Differential erosion and damaged stone graft on the side pediment*





Above and left:

Fig. 1 - Break outs on the right jamb of the gateway caused by vehicles

Fig. 2 - Broken off section of repair material

Fig. 3 - Relief structure from differential erosion on the pediment

Fig. 4 - Flaking surface on the tympanum

Fig. 5 - Granular disintegration on the surface of a pilaster section

Fig. 6 - Crack formation





Above and left:

Fig. 1 - Crust formation on the lower surface of the arch

Fig. 2 - Soiling from splashed paint on the jamb, high-water mark

Fig. 3 - Widened joint with chipped flanks on the cornice

Fig. 4 - Cracks in mortar repair work

Fig. 5 - Damaged repair work on the left jamb of the gateway



## 6. Project Planning for the Restoration of the Sandstone Portal

After the completion of the structural survey and structural condition assessment, recommendations were developed for the actual restoration of the portal. The recommended measures were examined with regard to technical and aesthetic suitability then assessed and reviewed based on criteria applied to the preservation of historic monuments.

First, several sample areas were identified on the pilaster which separates the gateway from the side entrance and on the right jamb of the side entrance. All types of damage observed on the portal were represented among the sample areas, allowing a "trial restoration" to be planned.

The work was to be performed in the winter months of 2005/06; therefore a compact climatized structure was built around the applicable areas of the portal.

*Right:*

*Fig. 1 - Cleaning of the sandstone surface using the micro-jet method*

*Fig. 2 - Application of poultices for reducing the salt content of the stone*

*Figs. 3-5 - The damaged cement mortar from previous repair work was removed, and new restoration mortar applied to the area. The repaired surfaces were then retouched.*

*Fig. 6 - Backfilling of plates, contour scaling and cracks*

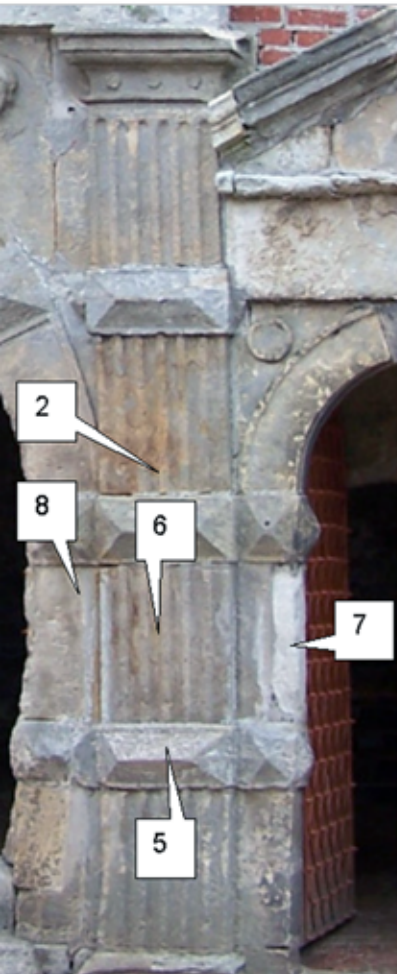

### Sample Areas

1. Cleaning of the sandstone surface using a micro-abrasive masonry cleaning system
2. Treatment with poultices to reduce the salt content - wherever possible with directed moisture flow
3. Removal of cement mortar jointing and repointing with hydraulic lime mortar
4. Application of silicic acid ester to strengthen areas affected by granular disintegration - marked in yellow on Damage Mapping
5. Removal of the cement mortar which had been used to replace a large section of missing stone; rebuilding of the damaged stone using stone repair compound (restoration mortar)
6. Removal of the cement mortar which had been used to repair several smaller flaws > Assessment of whether flaws require refilling > Rebuilding of the damaged stone using stone repair compound (restoration mortar) as necessary
7. Removal of a stone graft made from Cotta sandstone and creation of a new stone graft using Posta sandstone
8. Backfilling of a crack with injection material
9. Opening of the joint between the sandstone portal and the brickwork behind it > Evaluating whether a barrier (lead sheet) could be added between the sandstone and the brickwork

### Further investigations in the area of the sample axis

Frequent testing of the salt content before, during and after salt-reducing measures

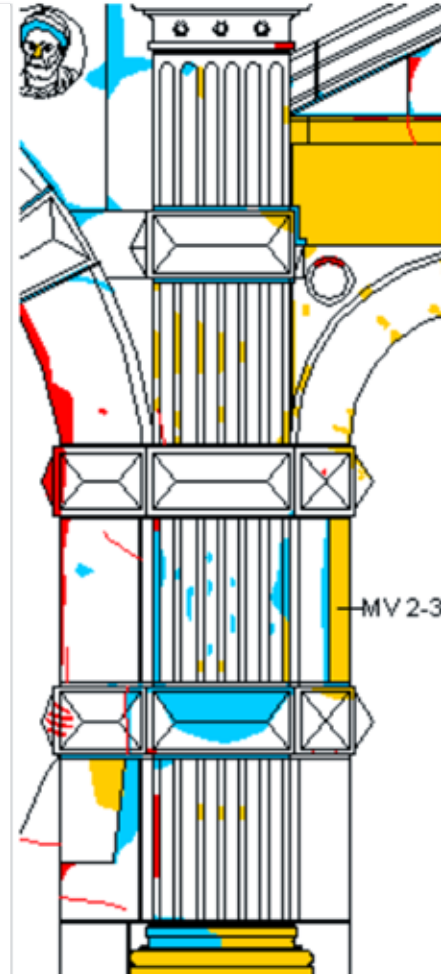

*Above - Sample Areas*

Fig. 7 - Pointing work

Figs. 8-10 - Following the removal of an older, clearly damaged section of repair mortar in the jamb the damaged surface of the stone was prepared using stonemasonry techniques and filled in with a structural element crafted from Posta sandstone (stone graft).

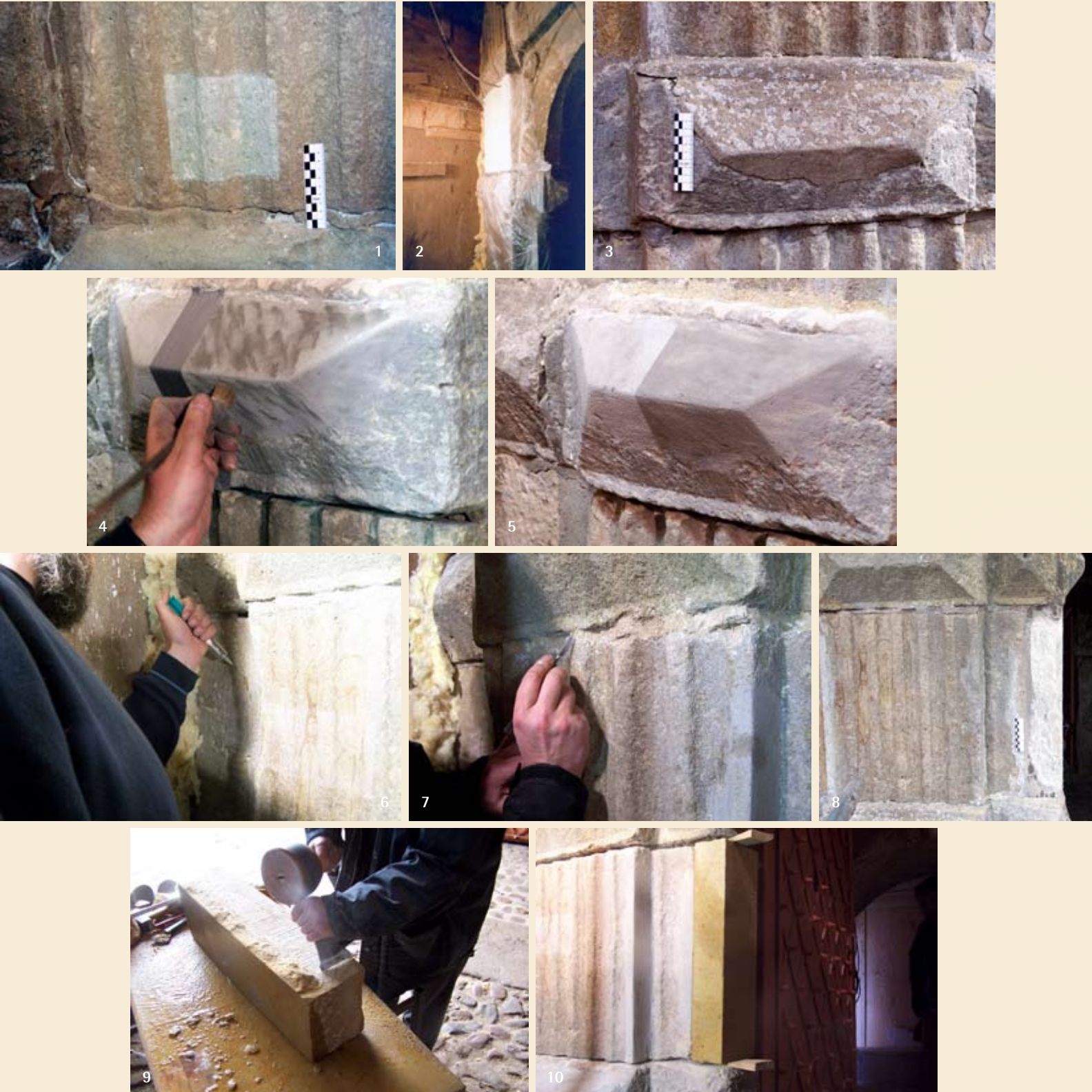



## 7. Restoration Measures



The restoration measures which were determined based on the preliminary investigations and structural condition assessment were successfully tested on the sample areas. It was then possible to begin restoration work on the portal in the summer of 2006.

### 7.1 Cleaning

All visible surfaces of the sandstone blocks which make up the portal were cleaned using a restorative micro-abrasive masonry cleaning system. This system uses compressed air and a nozzle to spray a dry mineral or organic abrasive against the surface to be cleaned. The friction produced by the powder against the surface breaks down surface impurities, leaving the surface clean. The abrasive, pressure, nozzle diameter and distance to the surface can be varied to achieve the desired cleaning intensity.

The objective of these cleaning measures was to remove or reduce the dust deposits, blackening and gypsum crusts on the sandstone surface in order to improve the diffusion behaviour and prepare for preservation measures.

Areas of heavier soiling which could not be cleaned away with the micro-abrasive system (e.g. paint) were removed using a scalpel.

*Below:*

*Fig. 1 - Micro-abrasive cleaning*

*Fig. 2 - Pilaster following cleaning work, with reference areas showing the condition of the surface prior to cleaning*



### 7.2 Reduction of the Salt Content

The sandstone blocks which form the pilasters and the jambs on either side of the gateway and side entrance were found to have high salt contents in some parts. The identified salts were a mixture of various nitrates and chlorides. Furthermore, along with gypsum, a relatively high sodium sulphate content was detected in some areas. This type of salt known to be especially damaging to building materials.

A salt-reduction treatment was carried out using a desalination poultice. This treatment is based on the transportation of salts from the rock into the poultices by means of a directed flow of moisture. For this purpose the treated stone is irrigated through integrated tubing from a water supply tank.

The desalination poultice used for this project contained perlite, sand, kaolinite and other components.

First, all cement mortar which had been used for earlier repairs on the portal was removed. Then holes ( $\emptyset$  6 mm and depth 200 mm) were drilled in 30cm intervals (wherever possible, in joints or in flaws which would be filled in later with repair mortar). Through these holes the stones were irrigated with special stainless steel cannulas through a system of silicone tubing.





The stones are irrigated with water for a period of approx. 3-4 days. Then water from the drying sandstone and brickwork is transported into the poultice material, carrying the dissolved salts. The time required for this process is weather-dependent (temperature, humidity, wind). After approx. 2 months the water (and salt) transport process

is complete. The poultice material is then dry enough to be removed mechanically. In order to evaluate the success of the desalination treatment, samples were taken from various depths of the brickwork and analysed in the laboratory.

*Below:*

*Figs. 1-2 - Irrigation system for desalination treatment*

*The poultice material is sprayed onto the cleaned surfaces of the sandstone and adjacent brickwork using a small plastering machine.*



*Above and right:*

*Fig. 3 - Application of desalination poultice*

*Fig. 4 - Portal and brickwork with desalination poultice*

*Fig. 5 - Desalination poultice during the drying phase*

*Fig. 6 - Sample removed for evaluating success of desalination treatment*





### 7.3 Dismantling and Re-setting of Severely Displaced Structural Elements

The masonry units of the coat of arms cartouche above the gateway, with the flanking volutes and the pediment, exhibited displacements of up to 4 cm. As a result of this displacement large gaps had formed between the masonry units and the brick wall behind them as well as in the joints between stones. These gaps had filled with humus. Plants were growing in this humus, and their roots were exerting pressure on the masonry units and contributing to additional displacement of the structure.

Therefore this entire portal section, down to the cornice, was dismantled and the structural elements re-set.

The solid masonry units were initially re-set, or re-laid, without mortar onto sheet-lead spacers. The masonry units were stabilised with anchors, braces and dowels made of 316 stainless steel (V4A) or brass. The joints between the masonry units were then sealed with tow (hemp) and filled in with liquid mortar. After the bedding mortar had set the tow was removed and the joints tuck-pointed. The three visible wrought-iron anchors of the coat-of-arms cartouche were restored and refastened.







Left and above:

Figs. 1-3 - Dismantling of the pediment above the gateway

Figs. 4/5 - Brickwork behind the dismantled pediment

Fig. 6 - Corroded anchor on the pediment

Figs. 7-12 - After the brickwork was cleaned the sandstone units were re-set. The iron anchors were restored.



#### 7.4 Plumbing Work

In addition to the rising damp and the moisture migration from the brick wall of the bastion, rainwater penetration was identified as another major cause for the weathering damage experienced by the sandstone structural elements. Therefore the top surfaces of the pediments above the gateway and the side entrance were covered with a layer of sheet lead (1.0 mm) for water run-off. In order to avoid blurring or distorting the profile lines the coverings were formed without locking strips and with a narrow protruding edge (approx. 1 cm).

The lead sheeting was attached using traditional techniques, with lead anchors and clips. On the rear edges of the covered surfaces, where the sheeting comes in contact with vertical elements, the sheeting was not flared up and secured against the rear element but simply pushed into the horizontal joint and held in place with lead wool.

*Below:*

*Figs. 1-3 - Application of the sheeting*

*Figs. 4/5 - Fastening of the sheeting with traditional melted lead*

*Fig. 6 - Sheetting on the top surface of the upper pediment*





Left and below:

*Figs. 1/2 - Sealing of joints with lead wool*

*Fig. 3 - Pediment with sheeting*

*Fig. 4 - Pediment above the gateway after re-setting*





### 7.5 Moisture Barrier between Portal Sandstone Elements and Brick Wall

In order to permanently stop the migration of moisture and associated salts from the brickwork the sandstone units that form the pilasters and the jambs of the gateway and side entrance were sealed off from the rear brickwork of the bastion and the entrance casemate.

For this purpose slots were chiselled in sections into the brickwork behind the sandstone units. A rolled lead sheet was pushed into the slot, covering the entire rear surface of the sandstone unit. The slots in the brickwork were then filled in with bricks and plastered.

*Below:*

*Fig. 1 - Sheet for sealing off the sandstone from the brickwork*

*Figs. 2/3 - Dismantling of the displaced pediment over the side entrance*

*Fig. 4 - The joints of the archway over the side entrance were sealed with lead in order to achieve a certain level of tension and stability.*

*Figs. 5/6+6a - The masonry units were initially re-set, or re-laid, without mortar onto sheet-lead spacers. The joints were then sealed with tow (hemp) and filled in with liquid mortar.*



## 7.6 Masonry Unit Replacement and Stone Grafts

Masonry unit replacement implies the complete removal of a masonry element and replacement with a newly fabricated element. This measure was required in the left pilaster of the sandstone portal, on the jamb of the gateway, and on the frieze and lower cornice of the pediment above the side entrance.

Traditional stonemasonry techniques were used to craft the new masonry units from Posta-type sandstone and set them in the portal.

The pediment above the side entrance, which was severely displaced and shifted toward the front, had to be completely dismantled down to the vaulted arch for the replacement of damaged masonry units. The usable masonry units were then re-set together with newly fabricated units.



Above:

*Figs. 1/2 - Left jamb following the removal of old stone grafts and cement-mortar repairs*

*Fig. 3 - Replacement of the upper section of the guardstone inside the left jamb*

*Fig. 4 - Left jamb with newly fabricated masonry units*





Stone grafts are used for repair work in partially damaged natural stone units; for such repairs a stonemason chisels out the damaged area (stone-graft placement site) for the fitting of a replacement piece (stone graft).

During earlier restoration work on the portal large flaws were repaired with stone grafts or filled in with plastered brickwork. Cotta-type Elbe sandstone was used for the stone grafts. The properties, in particular the weathering properties, for this type of sandstone differ greatly from those of the sandstones used for the original structure (Posta-type Elbe sandstones). All of the stone grafts made from Cotta sandstone were already showing signs of significant weathering damage.

These stone grafts, as well as the plastered brickwork, were removed and replaced with newly fabricated stone grafts.

The new stone grafts were made from Posta-type sandstone from the Mühlleite quarry; the macroscopic and physico-mechanical properties of this sandstone were found to be very similar to the sandstone of the original structure.

The stone grafts were dimensioned using traditional stonemasonry techniques, i.e. without sawn surfaces or profiles. The surfaces of the grafts were prepared using techniques similar to those used for the existing masonry units; for most of this work hand-forged tools were used. The stone grafts were fastened with dowels made of 316 stainless steel (V4A) and aligned using lead spacers, depending on the specific requirements of the repair. The joints were grouted and tuck-pointed with a hydraulic lime mortar.

*Below:*

*Figs. 1-4 - Stone grafts on pilaster and in the architrave area*



### 7.7 Strengthening Areas of Granular Disintegration

A silicic acid ester was used for consolidating structurally deteriorated areas near the surface of the sandstone unit which were disintegrating, flaking or eroding into cavernous pit. For this purpose the affected areas were flooded using syringes and cannulas. Areas adjacent to mortar repairs were also strengthened by pre-moistening.

Silicic acid esters (SAE) are liquids produced through the reaction of silicic acids with alcohol. During the strengthening process various reactions occur, ending with the reaction of SAE with water to yield alcohol and an amorphous silica gel. The newly formed alcohol, along with any solvent residues, evaporates, leaving behind the silica gel. The silica gel does not form a film that covers all of the pore walls; instead it primarily collects in the spaces between the grains of the rock. Consequently strength is added to the structure exactly where it is needed. A relatively small amount of material is sufficient for achieving significant strengthening of the material.

Various techniques can be used for the application of silicic acid esters to the surface of the stone. For both the sample areas and later restoration work the material was applied using injection syringes; with this method the consolidator can be very well-directed and precisely dosed. Generally the stone is saturated in repeated applications wet-in-wet.

### 7.8 Backfilling of Plates/Contour Scaling and Repair of Cracks

An injection mortar composed of silicic acid ester, fillers and glass beads in a fixed ratio was used for filling in smaller cracks and backfilling hollow layers and large scales. The injection mortar was mixed well to disperse individual components and then injected into the cracks and hollow layers with injection syringes; these areas had been pre-moistened with silicic acid ester prior to the application of the injection material. The silicic acid ester is used here as a binder which functions in the same way as in the strengthening treatments: through the secretion of an amorphous silica gel that cements the aggregates together and to the flanks of the cracks.

*Below:*

*Fig. 1 - Strengthening areas of granular disintegration on*

*the dismantled masonry units of the coat-of-arms plate*

*Fig. 2 - Application of injection material using a syringe*

*Fig. 3 - Crack following the application of injection material. The discolouration around the crack from the preliminary moistening with silicic acid ester recedes after the ester has fully cured and dried.*





### 7.9 Repair Work with Stone Repair Compounds (Restoration Mortars)

The cement mortar which had been used for stone replacement in earlier restoration work was removed. Mortar which had not already begun to loosen had to be chipped away mechanically. This work was performed with great care, ensuring that as much of the adjacent stone substance as possible was retained.

A stone repair compound with a silicic acid ester binder was used for closing small to medium-sized flaws and areas of back-weathering as well as filling in spaces around plates of detached stone and contour scaling. In order to improve the adhesion of the repair mortar the surface of stone to be repaired was pre-moistened with SAE, and a bonding agent was applied.

The patches were made flush with the surface. Shallow flaws only required a single application of material to attain the required level. For larger repairs, however, the material was applied in layers. In this case the surface of the lower layer was roughened before the next layer was applied in order to avoid leaving solid and smooth surfaces which could inhibit proper bonding.

### 7.10 Retouching Repair Work

The stone repair compounds used for the repair work were matched to the colour of the surrounding rock. For this purpose pigments were added to the dry mortar. Because the sandstone colour and degree of patination can vary greatly the repair compound was later retouched to harmonise with the adjacent rock.

This process involved the application of colour to the patches using dry silicate chalks; various shades of chalk were mixed on the surface of the patch to match it to the surrounding area. This retouching work was then fixed using a silicic acid ester.



Above and right:  
Figs. 1-5 - Patching flaws with  
stone repair mortar  
Figs. 6/7 - Retouching repair  
work

### 7.11 Joint Repair

Joints with either damaged bedding/pointing mortar or cement mortar were cleaned out. For this work the old joint material was carefully chiselled or scraped out by hand. Then the joints were thoroughly cleaned, and all dust residues were blown or suctioned out.

A hydraulic lime mortar was employed for the repointing work. For this mortar, sand with a grain size of 0 to 2 mm was used as an aggregate, and natural hydraulic lime along

with slaked lime was used as a binder in order to come as close as possible to the original mortar, which had been analysed in the preliminary investigations.

The earth-moist jointing material was pressed into the joints using pointing irons. After the curing process had begun the material was touched up with a scalpel to make the mortar flush with the surface.



Above and right:

Fig. 1 - Filling of joints with mortar

Fig. 2 - Pediment after completion of repair and jointing work

Fig. 3 - Portal during restoration work

Fig. 4 - Restoration Measure Mapping for the top section of the portal

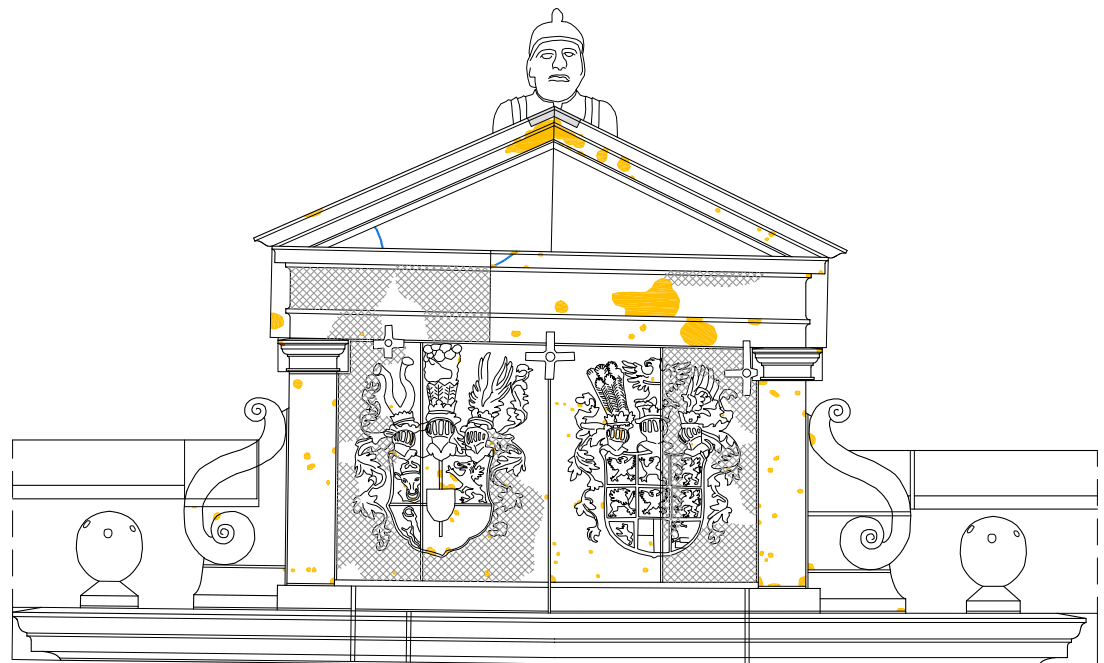

TYPE OF MAPPING		SITE	OBJECT	STRUCT. ELEMENT/AREA
RESTORATION MEASURE MAPPING		DÖMITZ FORTRESS	SANDSTONE PORTAL	VEWS
COLOUR	SYMBOL			
[Yellow]	[None]	PATCHING WITH STONE REPAIR COMPOUNDS (SAE BINDER)		
[Purple]	[None]	PATCHING WITH STONE REPAIR COMPOUNDS (CALCITIC BINDER)		
[Blue]	[None]	RECEMENTING OF BROKEN PIECES		
[Red]	[None]	CRACK REPAIR		
[Hatched]	[None]	AREAS STRENGTHENED WITH SAE		
[Grey]	[None]	STONE GRAFT		

DÖMITZ FORTRESS  
SANDSTONE PORTAL  
DIAGRAM OF REPAIR WORK 2006

Working Group  
Thomas Bolze, engineer  
Thomas Schuber, restorer



## 8. The Sandstone Portal Following Completion of Restoration Work







Left - Full frontal view after completion of restoration project

Above and right:

Fig. 1 - Finishing touches on the inside of the archway

Fig. 2 - Repaired gate jamb

Fig. 3 - Repair work with stone repair compound on the pilaster to the right of the gate

Fig. 4 - "Traces of use" preserved on the jamb of the gateway and conservative repair of break out





Above and right:

Fig. 1 - Portrait medallion with warrior, break-out on helmet patched with stone repair compound

Fig. 2 - Pediment over side entrance





*Left and above:*

*Fig. 1 - Side entrance jamb*

*Fig. 2 - Patch with stone repair compound on side entrance arch*

*Fig. 3 - View of pediment*



# Appendix



## Bibliography

BOLZE, TH. / SCHUBERT, TH.: Modernisierung und Instandsetzung der Festung Dömitz – Modellprojekt Sanierung Sandsteinportal, Potsdam, Berlin 04.04.2006  
Working group: Thomas Bolze, engineer, and Thomas Schubert, restorer

GRUNERT, S.: Der Sandstein der sächsischen Schweiz.- Paper from the Staatliches Museum für Mineralogie und Geologie in Dresden, Volume 37, Leipzig 1986

KUTSCHKE, D.: Steinbrüche und Steinbrecher in der Sächsischen Schweiz – Series published by the Stadtmuseum Pirna, Issue 11, Pirna 2000

NEUMANN, H.: Festungsbau – Kunst und Technik, Weltbild Verlag GmbH, Augsburg 2000

SCHARNWEBER, J.: Festung Dömitz im 1000jährigen Mecklenburg, Druck- und Verlagsgesellschaft Köhring & Co., Lüchow 1995

SCHARNWEBER, J.: Die Festung Dömitz, ein Ort für mecklenburgische Militärgeschichte? in Der Festungskurier, Volume I, Ingo Koch Verlag, Rostock 2001

SCHRÖDER, J.: Gutachten – Ergänzende Dokumentation zu der Untersuchung zum Erhaltungszustand und den Untersuchungsergebnissen am Festungsportal; Denkmalpflegerische Zielstellung und Sanierungsempfehlung, Rostock, Nov/Dec 2003, Jörg Schröder, restorer – VDR (German association of restorers)/ Rostock.

## List of Parties Involved

Project leadership:

GOS mbH – Treuhänderischer Sanierungsträger (fiduciary redevelopment agent) for the town of Dömitz, Manfred Kersten

Construction supervision:

Architekturbüro Michael E.A. Porep (architecture firm)

State Agency for the Preservation of Historical Landmarks, Lower Authority for Historical Sites

## Preliminary Investigations – Structural Survey – Restoration Concept

Working group

Thomas Bolze (engineer), Potsdam

Thomas Schubert (restorer), Berlin

together with

Dr. Angela Ehling, geologist, Federal Institute for Geosciences and Natural Resources (BGR), Berlin office – petrographic analyses

FEAD GmbH – Forschungs- und Entwicklungslabor für Altbausanierung und Denkmalpflege, Berlin – mortar and salt analyses

Gudrun Bolze, Ingenieurbüro Bolze (engineering firm), measurements and structural diagrams

## Restoration of the Portal

Working group

Thomas Bolze (engineer), Potsdam

Thomas Schubert (restorer), Berlin

together with

FEAD GmbH – Forschungs- und Entwicklungslabor für Altbausanierung und Denkmalpflege, Berlin – reduction of the salt content

Steinwerkstatt Alexander Reichelt (stone workshop), master stonemason and restorer, Potsdam – stonemasonry work

Claudia Arnold M.A., art historian, Berlin – documentation of restoration work

Philipp Bolze, Restaurierungswerkstatt Thomas Schubert (restoration workshop), master plumber and metal restorer – plumbing work

Kathrin Stein, Restaurierungswerkstatt Thomas Schubert (restoration workshop)

Anett Lüdicke (restorer), Ingenieurbüro Bolze (engineering firm)

Gudrun Bolze, Ingenieurbüro Bolze (engineering firm)

# Imprint

## Publisher:

Town of Dömitz  
Goethestrasse 21, 19303 Dömitz, Germany  
www.doemitz.de  
www.festung-doemitz.de  
Tel. +49 (0) 3 87 58 - 3 16 0  
Fax +49 (0) 3 87 58 - 3 16 55

## GOS mbH

Treuhänderischer Sanierungsträger  
(fiduciary redevelopment agency)  
for the Town of Dömitz  
Platz des Friedens 2, 19288 Ludwigslust, Germany  
www.gos-gsom.eu  
Tel. +49 (0) 38 74 - 57 08 00  
Fax +49 (0) 38 74 - 4 73 46  
e-mail: ludwigslust@gos-gsom.eu

## Editors:

Annette Brandes, GOS mbH  
Manfred Kersten, GOS mbH



## Contact:

City of Kostrzyn, Lead Partner  
Mrs. Agnieszka Żurawska-Tatała  
Tel. +48 (0) 95 - 7 27 81 24  
Fax +48 (0) 95 - 7 27 81 93  
e-mail: zurawska@kostrzyn.um.gov.pl

## Projekt Coordination:

Hartmut Röder  
Tel. +49 (0) 30 - 92 37 21-0  
e-mail: h.roeder@gku-se.de

Dr. Hans-Rudolf Neumann  
Tel. +49 (0) 30 - 31 47 23 88  
e-mail: hrv.neumann@t-online.de

## Projekt Homepage:

www.bfr.pl

## Texts:

Thomas Bolze (engineer)  
Bruno-Taut-Strasse 7C, 14469 Potsdam, Germany  
Tel. +49 (0) 3 31 - 270 47 25  
Fax +49 (0) 3 31 - 270 46 79  
e-mail: thomas.bolze@t-online.de

## Photographs and illustrations:

All photographs were taken by Thomas Bolze (engineer),  
Potsdam, during the construction period from 2005  
to 2007 (unless otherwise credited).

## Graphics:

www.designmuehle.com

## Printing:

Digital Design, Schwerin

November 2007, 1st edition, 500 copies

## Previous Publications:

Issue 1 "Festung Dömitz" with chronological table  
- December 2006, 1st edition, 500 copies  
Issue 2 "Festung Dömitz" Bauteil Sandsteinportal  
- Mai 2007, 1st edition, 500 copies

## Scientific partners:

European University - Viadrina Frankfurt/Oder  
R. S. Dornbusch, M.A.  
www.ziw.euv-frankfurt-o.de/sek/

Humboldt-University at Berlin  
Dr. F. Riesbeck  
www.agrar.hu-berlin.de

Immanuel Kant State University of Russia  
Dr. E. Kropinova  
www.albertina.ru

Vytautas Magnus University Kaunas  
Dr. V. Rakutis  
www.vdu.lt

Kaunas University of Technology,  
Institute of Architecture and Construction  
Dr. K. Zaeckis  
www.asi.lt







## Baltic Fort Route

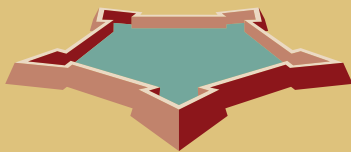

This project is part-financed by the European Union  
(European Regional Development Fund)  
within the BSR INTERREG III B programme



### Fortification Town partners:

Kostrzyn nad Odrą - Fortress Kostrzyn  
Municipality of Kostrzyn nad Odrą  
[www.kostrzyn.um.gov.pl](http://www.kostrzyn.um.gov.pl)

Dömitz - Fortress Dömitz  
Municipality of Dömitz  
[www.doemitz.de](http://www.doemitz.de)

Berlin - Citadel Spandau and Fort Hahneberg  
Department Spandau of Berlin (Citadel of Spandau)  
[www.zitadelle-spandau.de](http://www.zitadelle-spandau.de)

Peitz - Fortress Peitz  
Association Museum of City Peitz  
Förderverein für die Museen der Stadt Peitz e. V.  
[www.museumsverein-peitz.de](http://www.museumsverein-peitz.de)

Gorgast - Fort Gorgast  
Association "Fort Gorgast"  
[www.fort-gorgast.de](http://www.fort-gorgast.de)

Kołobrzeg - Fortress Kołobrzeg  
Municipality of Kołobrzeg  
[www.kolobrzeg.pl](http://www.kolobrzeg.pl)

Gdańsk - Fort Grodzisko  
Culture Park of City Fortifications, Fortress Gdańsk  
[www.grodzisko.pl](http://www.grodzisko.pl)

Gdańsk - Fortress in Vistulamouth  
Historical Museum of Gdańsk  
[www.mhmg.gda.pl](http://www.mhmg.gda.pl)

Nowy Dwór Mazowiecki - Fortress Modlin  
Municipality of Nowy Dwór Mazowiecki  
[www.nowydwormaz.pl](http://www.nowydwormaz.pl)

Giżycko - Fortress Boyen  
Municipality of Giżycko  
[www.gizycko.pl](http://www.gizycko.pl)

Świnoujście - Fortress Świnoujście  
Municipality of City Swinoujscie  
[www.swinoujscie.pl](http://www.swinoujscie.pl)

Kaunas - Fortress Kaunas  
Municipality of City Kaunas  
[www.kaunas.lt](http://www.kaunas.lt)

Kaliningrad - Fortress Kaliningrad  
Kaliningrad Oblast Administration  
[www.gov.kaliningrad.ru](http://www.gov.kaliningrad.ru)